

WIRING A RELAY FOR 1997-1999 SATURN FACTORY DISARM

- ▶ On 1997-1999 Saturn models, there is not an external factory alarm disarm wire. The factory alarm can only be armed and disarmed with the factory remote.

IN ORDER TO KEEP THE FACTORY ALARM ACTIVE WHEN THE VEHICLE IS REMOTE STARTED, THE FOLLOWING STEPS MUST BE PERFORMED:

- 1 Locate the factory alarm module. It can be found behind the panel net to the driver's rear seat.
- 2 Use a relay to isolate the PINK (ignition input) wire and interface the YELLOW/BLACK (starter kill output) wire as shown using the remote start's (-) ground when remote started wire.

NOTE: This procedure will also allow the factory remotes to function when the vehicle is remote started.

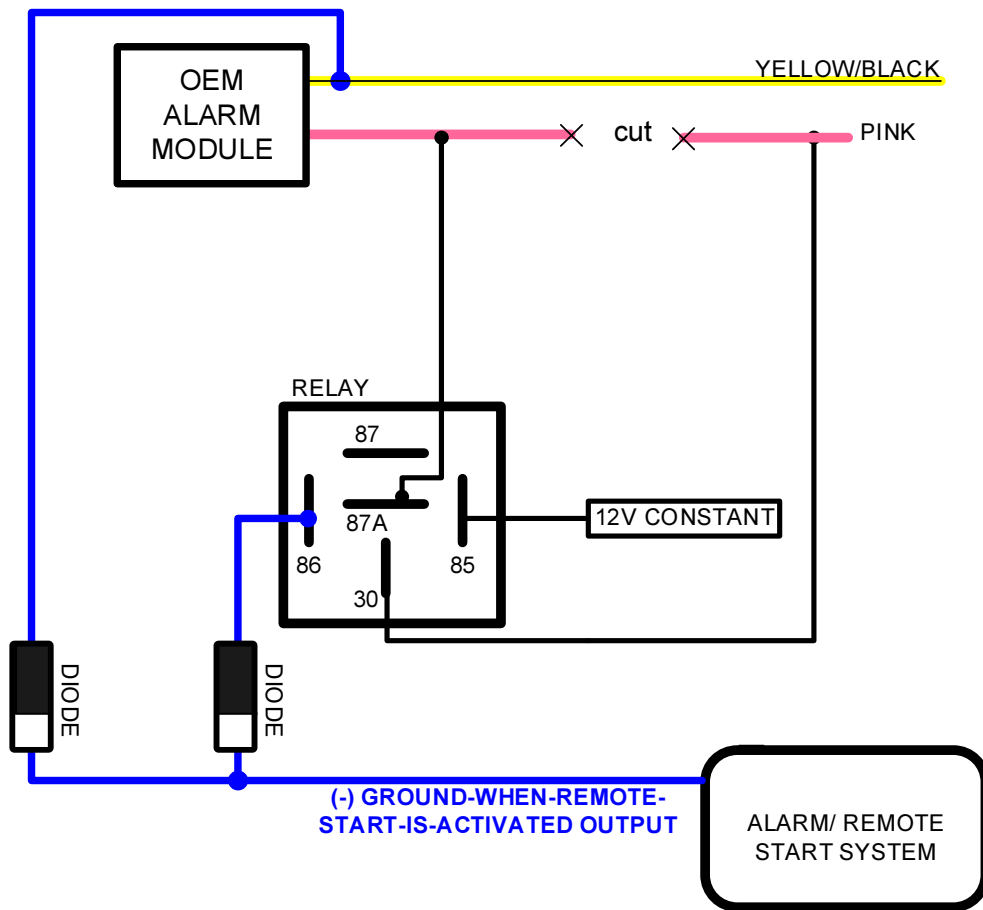

PIN	CONNECTION
85	TO 12V CONSTANT
86	TO (-) GROUND-WHEN-REMOTE-START-IS-ACTIVATED OUTPUT
87	NO OUTPUT
87A	TO PINK WIRE – OEM ALARM MODULE SIDE
30	TO PINK WIRE – CAR SIDE

Remote starter and security installations should be attempted by experienced security installers only. Information contained is accurate to the best of our knowledge and experience. Information contained is without any representation of warranty. It is the installer's responsibility to test and confirm all circuits with a digital multi-meter. Proper installation remains the responsibility of the installer. CarInstallExperts.com assumes no liability or responsibility resulting from an improper installation, even in reliance with the information contained in this guide.